

SWING CHECK VALVES

BRONZE SWING CHECK VALVE METAL SEAT - INCHES

3010

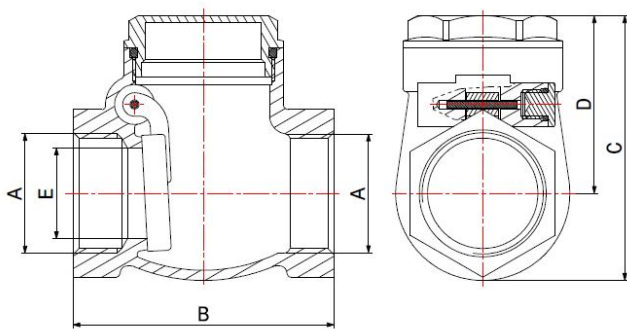
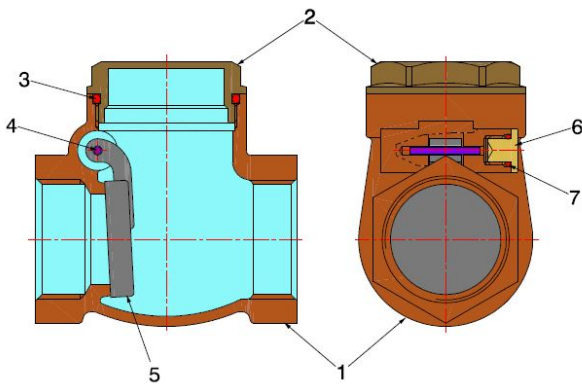

COMPONENTS

POS.	PART NAME	N°	MATERIAL
1	Body	1	Bronze CC491K UNI-EN 1982:2000
2	Cap	1	CW617N (1/2') UNI-EN 12164 - CW617N (da 3/4' a 4') UNI-EN 12165
3	Cap O-Ring	1	NBR
4	Pin	1	CW617N UNI-EN 12164
5	Clapet	1	CW617N UNI-EN 12165
6	M8 Cap	1	CW617N UNI-EN 12164
7	O-Ring	1	NBR

DIMENSIONS INCHES

A	B	C	D	E	PSI
1/2"	2,165	2,087	1,417	0,551	200
3/4"	2,441	2,520	1,693	0,787	200
1"	2,835	2,874	1,929	0,984	200
1.1/4"	3,228	3,346	2,244	1,181	200
1.1/2"	3,543	3,740	2,480	1,378	200
2"	4,134	4,213	2,717	1,850	200
2.1/2"	4,921	5,039	3,228	2,362	200
3"	5,669	5,709	3,583	2,913	200
4"	6,929	7,559	4,843	3,740	200

PACKAGING

	1/2"	3/4"	1"	1.1/4"	1.1/2"	2"	2.1/2"	3"	4"
CODE	3010010D00	3010010E00	3010010F00	3010010G00	3010010H00	3010010I00	3010010J00	3010010K00	3010010M00
PCS BOX	15	10	6	-	-	-	-	-	-
PCS CARTON	120	80	48	40	35	20	14	6	4